

**SOUND
MAGUS**

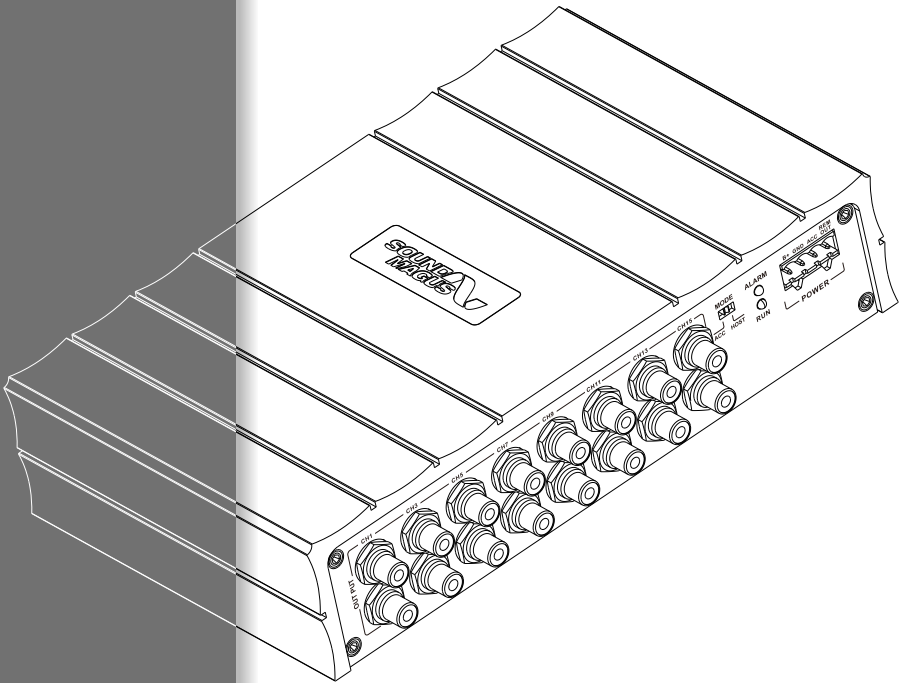

EP12S / EP16S

Owner's Manual **EN**

用户手册 **CN**

FEATURES

- Adopts 4-layer composite PCB board architecture design to effectively suppress EMC interference.
- Adaptive full screen graphical UI intelligent tuning PC software
- Japanese Rubycon audio dedicated filter capacitor
- ADI automotive grade SigmaDSP digital audio signal processor chip
- AKM audiophile grade audio dedicated DSP chip, Hi Fi grade ADC/DAC
- Ultra low distortion operational amplifier
- Intelligent high-level input detection technology to avoid the inability to use the on-board computer due to error messages.
- Multiple high-level signal inputs, supporting arbitrary mixing between multiple channels
- Each channel supports 31-band EQ; support customize multiple groups of joint adjustments on EQ, X-over, phase, delay.
- Built in 5.1 Bluetooth for direct digital audio transmission.
- Expandable external CSR Bluetooth 5.0 module, supports AAC, APTX-L, APTX-LL, APT-HD, MP3, SBC and other protocols.
- Main/auxiliary sound source intelligent mixing function, automatically detects the original car sound source signal and the later installed sound source signal, achieving free switching and automatic mixing
- Supports iOS/Android phone app tuning
- Support encrypting DSP settings to prevent unauthorized modifications
- Intelligent under-voltage protection circuit

EP12S INTERFACE AND FUNCTION INTRODUCTION

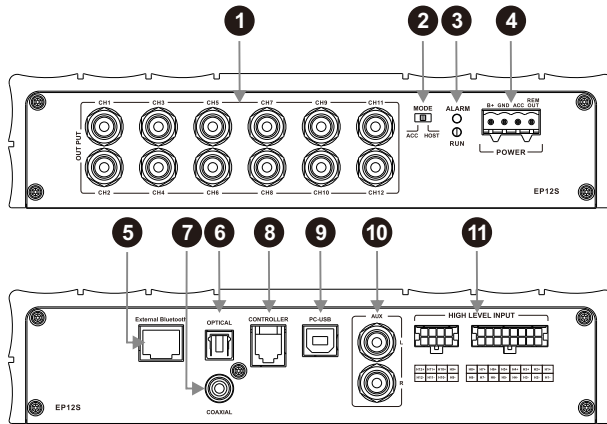

1. RCA audio output interface

Preamplifier analog signal output terminal, Output preamplifier analog signal to amplifiers or other audio systems.

2. Turn on mode selection

When choose "ACC", the device is started by the original vehicle's ACC signal; When choose "HOST", The device is started by CH1 of the high-level input signal.

3. RUN LED: Work indicator light. When the device completes self check and enters normal working state, the blue indicator light is always on.

ALARM LED: Protection status indicator light. When the protection indicator light flashes, it indicates that the device is in an abnormal working state and there is no output signal.

4. Power :

B+: It is used to connect to the automobile battery + terminal. To ensure an adequate supply of power in the DSP processor, please use a dedicated cable directly connected to battery + terminal. The cable must be connected with a fuse in line near 20cm of battery + terminal.

GND: It is used to connect to the ground cable of the DSP processor. The power supply ground wire needs to be firmly connected to nearby places with good conductivity such as the chassis, girders. Please use the cable with same specifications as the power cable.

ACC: It's used to connect to the switch control remote output signal from the audio equipment such as Car CD/DVD. The product will switch turn on/off automatically with the audio equipment.

REM OUT: It provides separate REMOTE signal output to other amplifiers to control other amplifiers switch turn on/off.

5. External Bluetooth Connector

For optional High-definition Bluetooth as input signal, and also connect to the mobile app for wireless tuning.

6. Optical input jack

Connect the car audio optical fiber cable, switch the audio source of the machine to the optical signal input to play the optical digital signal.

Note: This interface cannot be multiplexed with coaxial input interface.

7. Coaxial input interface

Connect the car audio coaxial cable, switch the audio source of the machine to the coaxial signal input to play the coaxial digital signal.

Attention: Please choose a coaxial line with an impedance of 75 Ω; This interface cannot be multiplexed with optical input interface.

8. Wired remote controller interface

Connect to optional wired remote controller to adjust the total volume and subwoofer volume, to select the main/auxiliary sound sources and preset sound effects.

9. USB 2.0 interface

Connect to a computer through a USB 2.0 cable for professional tuning operations and settings.

10. AUX interface

2 Channel RCA audio signal inputs which can be connected to the RCA audio signal output of car audio player.

11. High level input interface

Connect the HIGH-LEVEL IN to the speaker output interface of the car audio player.

EP16S INTERFACE AND FUNCTION INTRODUCTION

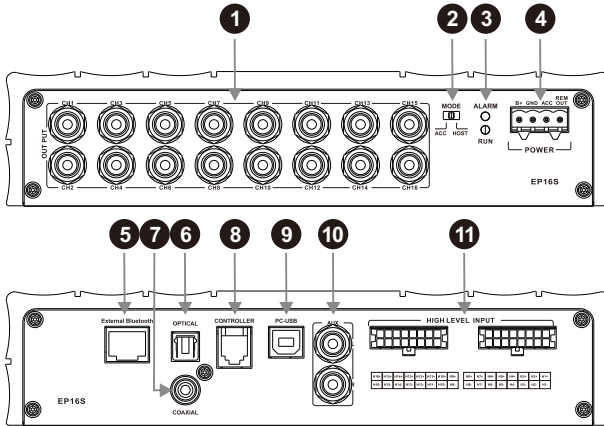

1. RCA audio output interface

Preamplifier analog signal output terminal, Output preamplifier analog signal to amplifiers or other audio systems.

2. Turn on mode selection

When choose "ACC", the device is started by the original vehicle's ACC signal; When choose "HOST", The device is started by CH1 of the high-level input signal.

3. RUN LED: Work indicator light. When the device completes self check and enters normal working state, the blue indicator light is always on.

ALARM LED: Protection status indicator light. When the protection indicator light flashes, it indicates that the device is in an abnormal working state and there is no output signal.

4. Power :

B+ :It is used to connect to the automobile battery + terminal. To ensure an adequate supply of power in the DSP processor, please use a dedicated cable directly connected to battery + terminal. The cable must be connected with a fuse in line near 20cm of battery + terminal.

GND: It is used to connect to the ground cable of the DSP processor. The power supply ground wire needs to be firmly connected to nearby places with good conductivity such as the chassis, girders. Please use the cable with same specifications as the power cable.

ACC:It's used to connect to the switch control remote output signal from the audio equipment such as Car CD/DVD. The product will switch turn on/off automatically with the audio equipment.

REM OUT:It provides separate REMOTE signal output to other amplifiers to control other amplifiers switch turn on/off.

5.External Bluetooth Connector

For optional High-definition Bluetooth as input signal, and also connect to the mobile app for wireless tuning.

6.Optical input jack

Connect the car audio optical fiber cable, switch the audio source of the machine to the optical signal input to play the optical digital signal.

Note: This interface cannot be multiplexed with coaxial input interface.

7.Coaxial input interface

Connect the car audio coaxial cable, switch the audio source of the machine to the coaxial signal input to play the coaxial digital signal.

Attention: Please choose a coaxial line with an impedance of 75 Ω; This interface cannot be multiplexed with optical input interface.

8. Wired remote controller interface

Connect to optional wired remote controller to adjust the total volume and subwoofer volume, to select the main/auxiliary sound sources and preset sound effects.

9.USB 2.0 interface

Connect to a computer through a USB 2.0 cable for professional tuning operations and settings.

10.AUX interface

2 Channel RCA audio signal inputs which can be connected to the RCA audio signal output of car audio player.

11.High level input interface

Connect the HIGH-LEVEL IN to the speaker output interface of the car audio player.

INSTALLATION

1. Turn the amplifier upside down.
2. Use eight screws from the standard accessories to install four fixtures on the amplifier (Fig. 1). According to the actual installation position of the amplifier, you can flexibly select vertical (installation 1) or horizontal (installation 2) fixtures to install on the amplifier.
3. Use four black screws from the standard accessories to fix the amplifier to the installation position.

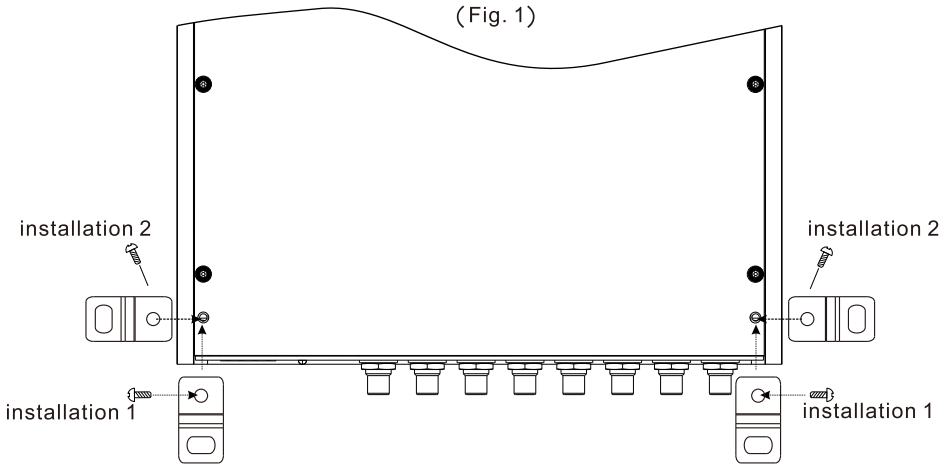

CONNECTION OPERATION

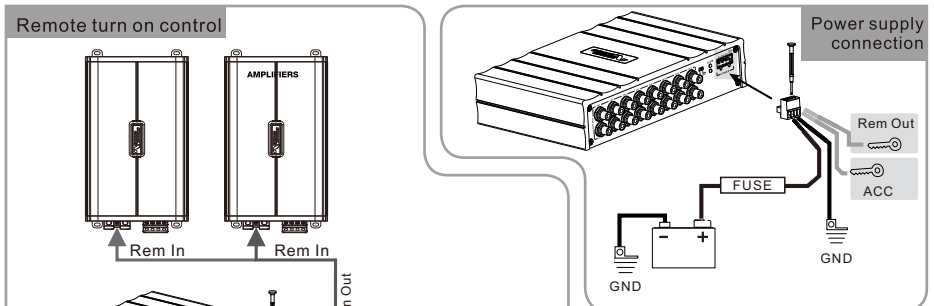

Caution: Before connection, please make sure that the power supply meets the power requirements of equipment. Connect strictly according to the instructions of the equipment otherwise, it may damage the equipment and may cause an accident. Between the battery and equipment must be connected with a fuse in line near 20CM of battery + terminal.

How to control DSP Turn ON/OFF

It provides 2 boot modes for customer's options which are ACC and HOST. For two modes of function introduction, Please refer to the "INTERFACE AND FUNCTION INTRODUCTION" item.

PC SOFTWARE INSTRUCTIONS

This function is only for use by manufacturers and distributors.

Software installation precautions

1. The software can only be used under the Microsoft® Windows® operating system.

Configuration requirement for PC:

Operating system: Windows XP/Windows 7/Windows 8/Windows 10

CPU: 1.6GHz or higher

Memory card: 1GB or higher

Hard Disk: 512MB or more free space

Computer screen resolution: 1280 * 768 or higher



Soundmagus

2. Before connecting the machine to the computer, please install the EP series computer software correctly.

Interface Introduction

Double click on the Soundmagus software on the computer desktop to enter the software startup interface.

First, select the model number being operated on, then enter the main interface, and after successful connection, perform detailed tuning operations.



Startup interface, select device

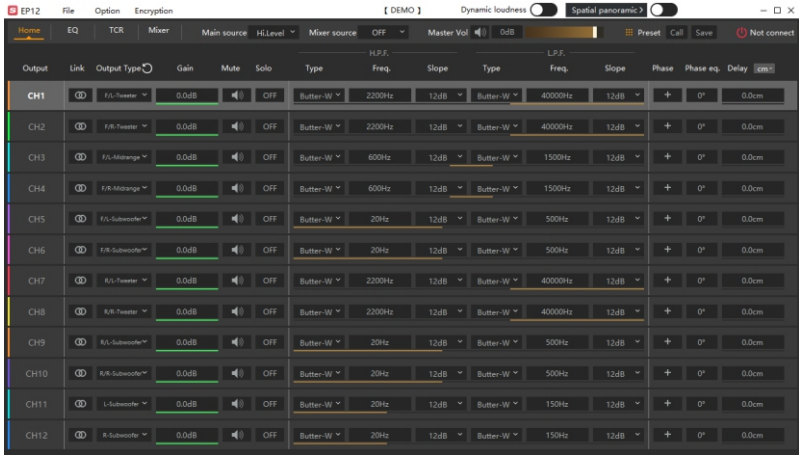

Main interface

Function introduction

When not online, the connection icon will display red Not connect

After the connection is successful, the connection icon will show green. Not connect

Menu: Files, Options, and Encryption.

1. Click [File].

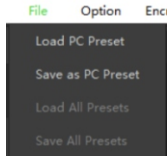

1.1 Load PC Preset

The scene file previously saved on the computer can be loaded as the current machine working scene.

1.2 Save as PC Preset

The current machine work scene file can be saved to the computer for later recall.

1.3 Load All Presets

Load the files of the entire machine previously saved on the computer to the machine (including the current working scene, machine preset scene, output channel configuration data, etc.), and copy all the machine data that has been debugged to the currently connected machine.

1.4 Save All Presets

Save all data on the current online machine as a computer file (including the current working scene, machine preset scene, output channel configuration data, etc.) for later recall when the whole machine is copied.

2. Click [Option]

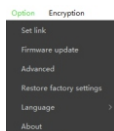

2.1 Select "Set link" to enter the link settings interface, select the function item that needs to be linked, and after checking it, you can perform link setting on the selected function on the homepage.

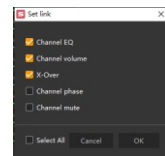

2.2 Select "Firmware Update", select the upgrade file in the pop-up dialog box, and then click the "Update" button to upgrade the firmware. If the upgrade progress reaches 100%, it indicates that the firmware upgrade is successful. After the update is completed, the machine will automatically restart to work.

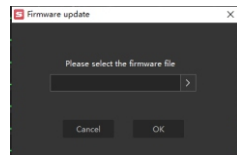

2.3 Select the "Advanced" option to set the "Main Source Attenuation" separately. The greater the attenuation of the main sound source, the lower the main volume, adjustable value: 0%~100%, with a default of 50%; Noise gate switch; Shutdown delay of 0-255 seconds; Dynamic bass switch.

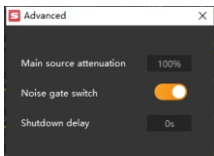

- 2.4 Select "Restore Factory Settings" to restore all the data set in the machine to the factory default state.

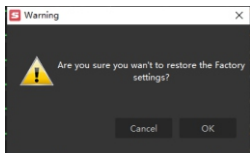

- 2.5 Select "Language" to switch between Chinese and English.

- 2.6 Select "About" to view device model and version.



3. Click "Encryption":

Encryption: Enter a 6-digit encryption password in the pop-up dialog box to encrypt the adjusted sound effect data.

Encrypted data can be decrypted by clicking "Decrypt" and entering the correct password; In the decryption interface, click "Clear Data" to release the encryption status with one click and restore the data to its factory state.

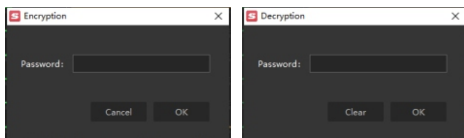

Main Source Selection

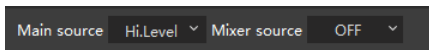

1. Main source: Click on the dropdown button on the right side of the Main source, And select the main source in the pop-up window: High level, Low level, Optical, Coaxial, Or Bluetooth

2. Mixer source (auxiliary sound source)



- 2.1 Mixer source: Click on the dropdown button on the right side of the Mixer source, and select the mixer source in the pop-up window: high level, low level, optical, coaxial, Bluetooth or OFF. Default is OFF.

- 2.2 When both main source and the mixer source are selected, you need to adjust the main source attenuation in the "Advanced" option according to the actual use needs. The larger the main source attenuation percentage value is, the smaller the main volume is. The adjustable value is 0%~100%, and the default value is 50%.

※ Note: When the current audio source mode is selected, the audio source mode can no longer be superimposed, otherwise the Mix source is invalid.

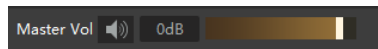
Master volume setting



You can press and hold the left button of the mouse to move the fader left or right or scroll the mouse wheel to set the volume. You can also directly enter the desired value to adjust it. The adjustment range is -60dB (off)~6dB, with a default of 0dB. Click the total volume speaker button() to mute the total volume, click again to unmute(), and adjust the total volume to automatically unmute.

Dynamic loudness and Spatial panoramic setting

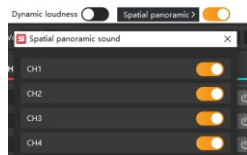

Dynamic loudness: Turn on the dynamic loudness switch, which can achieve a strong low-frequency dynamic effect with a small gain.

Spatial panoramic: Turn on the spatial panoramic switch, you can click on the drop-down menu, up to 12 channels can be controlled on/off, and then configure the corresponding panorama sound parameters.

Preset Sound Effect Settings

There is storage space for 6 sets of preset sound effects inside the machine. Click the call button or save button to set 6 sets of preset sound effect data.





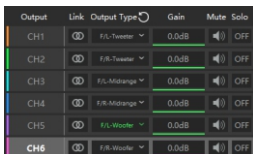

Link, Output type, Gain, Mute and solo settings

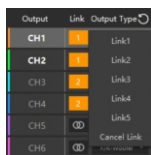

1. Link: Click the link button (), and in the pop-up dialog box, select the name of the link group. At this time, the Link icon next to the channel displays the corresponding group name serial number. You can freely set 5 link groups, and groups with the same group name serial number indicate that they are in the joint debugging state. If no joint debugging is required, you can choose "Cancel Link".



Attention: The items for joint debugging must be pre checked in the Set Link list, please refer to "Set Link" 2.1 for details.

2. Output Type: Click the Output Type button (). Select the channel type from the drop-down menu. There are tweeter, midrange, woofer, subwoofer and full-range options in the front; tweeter, midrange, woofer, subwoofer and full-range options are available in the rear; F/C-tweeter, F/C-midrange, R/C-tweeter and R/C-midrange options are available in the center; L-subwoofer, R-subwoofer and C-subwoofer options are available in the subwoofer; L-surround options are available in the surround.
If you need to reset each channel type, you can choose () to clear it or set it as default.
3. Channel Gain: The volume of the channel can be set by directly entering desired values, scrolling the mouse wheel, and using the up and down keys on the keyboard. The adjustment range is -60dB to 0dB, with a default of 0dB
4. Mute: Clicking on the volume speaker button () can mute the channel.
5. Solo: Clicking on the channel OFF button will enable the channel to have signal output, and the status button will display ON; At the same time, other channels switch to silent mode and displayed as. ()

X-over settings

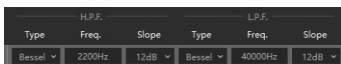

1. Type settings: Link-Ril, Butter-W and Bessel.

2. Frequency setting: Frequency can be adjusted by directly entering desired values, scrolling the mouse wheel, using up and down keys on the keyboard, Or clicking "H" or "L" on EQ while holding down the left mouse button and dragging.

Adjustable range:

EP12S: 20Hz~40000Hz;
EP16S: 20Hz~40000Hz;

3. Slope: 6dB/Oct, 12dB/Oct, 18dB/Oct, 24dB/Oct, 30dB/Oct, 36dB/Oct, 42dB/Oct, 48dB/Oct or OFF
Note: When the slope is 6dB/Oct, the Type is displayed as "Null".

Phase, Phase equalization, and Delay settings

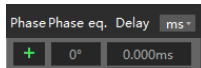

1. Phase: Click the "+" or "-" button to switch the phase of the channel to 0/180 °
2. Phase equalization: The output channel can be individually adjusted for phase equalization, with an adjustable range of 0 °~360 ° to solve the small phase shift generated during the tuning process.
3. Delay: The delay can be adjusted by directly entering desired values, scrolling the mouse wheel, and using the up and down keys on the keyboard. For more delay settings, please go to the delay interface. You can directly enter desired values, scroll the mouse wheel, use the up and down keys on the keyboard, or drag the slider to adjust the delay.

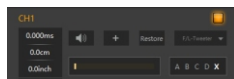

- 3.1 Delay groups: Each channel can choose to set up 4 delay groups, which can be cancelled by clicking "X".
- 3.2. Delay units: milliseconds, centimeters, inches.
- 3.3. Adjustment range: 0-20 milliseconds, 0-692 centimeters, 0-272.8 inches.
- 3.4. If you need to reset, you can click "Reset".

EQ settings

EQ has two interfaces: graphical equalization and parametric equalization



Graphical Equalization



Parametric Equalization

Each channel has 31 independently adjustable EQ segments. In the "Parametric Equalization" state, when the mouse moves to the frequency point that needs to be adjusted and pressed, the gain of the equalizer can be adjusted by dragging up and down, and the frequency of the equalizer can be adjusted by dragging left and right; When the mouse moves to the orange small box on the left and right sides of the picked frequency point, hold down and pull left and right to adjust the Q value of the equalizer. Frequency, Q value, and gain can also be set by directly entering desired values, scrolling the mouse wheel, and using the up and down keys on the keyboard.

1. Frequency adjustment range: 20Hz~40KHz;
2. Q value adjustment range: 0.404~28.852, default 1.902;
3. Gain adjustment range: -12dB~+12dB, default to 0dB.

When the channel EQ is adjusted, the "Bypass" equalization button will appear. Clicking on "Bypass" or the "Bypass" small dots will make all equalizers of the current channel inactive; Click the "Restore" equalization button to return all equalizers in the current channel to the last set state. Click the "Reset" equalization button, and all equalizer parameters for the current channel will return to their initial state. In the parametric equalization mode, the frequency, Q value and gain are adjustable, while in the graphic equalizer mode, the frequency and Q value are fixed, and only the equalizer gain can be adjusted.

Mixer settings

The EP series models all come with mixer function. First, set the sound source, then switch to the mixer interface, and set the signal to enter each channel of the audio processor through the selected sound source. The volume ratio of the signal to each output channel can be set separately, and the mixing purpose can be achieved by adjusting the volume ratio of each sound source in the channel.

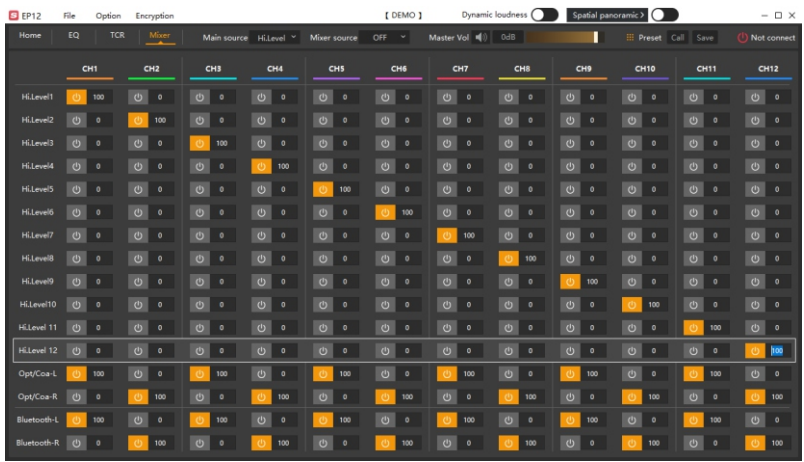

RTA: (Only available for EP16S)

This window displays the spectrum dynamics of the output channel.

1. Display window: The window size can be the largest screen and can be zoomed freely.

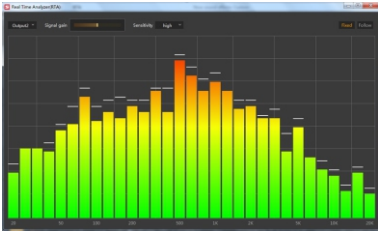

2. Select the display channel:

- (1)Output: Click the drop-down list to select the spectrum dynamics of the output channel.
- (2)Fixed: Only the spectrum dynamics of the currently selected output channel can be displayed, and other output channels cannot be switched.
- (3)Follow: Follow the output channel clicked by the mouse to switch and display the spectrum dynamics of the selected output channel.
- (4)Signal gain: hold down the mouse and push the fader left and right to adjust the signal gain.
- (5)Sensitivity: There are high, medium and low options. The higher the sensitivity, the more sensitive the frequency spectrum jumps.

Wired controller

- 1.3 inch OLED screen display
- Supports total volume adjustment
- Support Subwoofer volume adjustment
- Support one-click mute
- Support audio source switching
- Support recall preset sound effect data
- Interface mode: RJ11

- 1.Wired controller operation instructions

- 1.1.When the remote control is connected and started normally, the dynamic startup interface is displayed as shown in Figure 1.

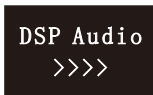

Figure 1

- 2.2.Main interface

After startup, enter the main interface of the remote control: the total volume adjustment interface (which can display the input sound source type). As shown in Figure 2-1, the volume can be adjusted by rotating the remote control knob. The volume increases clockwise and decreases counterclockwise, with a volume range of 0-66. Short press the knob to achieve mute operation when at total volume interface state. The mute interface is shown in Figure 2-2



Figure2-1



Figure2-2

- 3.Input audio source selection

Long press the knob on the main interface to enter the input audio source interface as shown in Figure 3. By rotating the remote control knob to select the input sound source. Long press the knob to exit the interface and return to the main interface.



Figure3

Note: If no operation is performed on the controller for around 5 seconds, the controller will automatically exit the corresponding interface and return to the main interface.

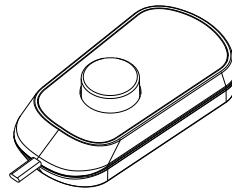

- 4.Recall preset sound effect data

Short press the knob to enter the DSP preset interface as shown in 4-1. The controller can display the preset sound effect group, and ESC is used to exit the call. Select the desired sound effect by rotating the button, and short press the button to call it. The call interface is shown in Figure 4-2. After the call is completed, it will automatically exit the interface and return to the main interface..



Figure4-1



Figure4-2

- 5.Subwoofer volume adjustment

Short press the knob to enter the subwoofer volume adjustment interface as shown in Figure 5. Rotate the button to adjust the subwoofer volume. The volume increases clockwise and decreases counterclockwise, with an adjustment range of 0~60. Long press the knob to exit the interface and return to the main interface.

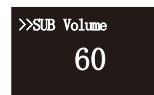

Figure5

EP12S Specification

Power supply	
Operating Voltage range	7.5 - 16V DC
Auto Turn On	ACC / DC OFFSET (High level input CH1 only)
Standby current	<0.5mA
Ldling current	0.75A
REM OUT output voltage	12V DC (380mA)
Input	
Analog input	12 Channel High Level / 10Vrms
	2 Channel Low Level (AUX) / 2.0Vrms
Digital audio input	1 Optical ; 1 Coaxial
Input Impedane	20K Ohm (Low Level) / 4.7 Ohm(High-Level)
Bluetooth	Built-in Bluetooth 5.1, Supports SBC / AAC protocols
	External Bluetooth 5.0, Supports AAC, APTX-L, APTX-LL, APT-HD, MP3, SBC and other protocols
Output	
Output Channel	12 Channel Low Level
Low level output channel	Output Level 5Vrms (14.4V , 1KHz , 1%THD)
Frequency Response ragnge	20Hz ~ 40KHz (-3dB)
THD (1KHz, 1Vrms output)	0.015%
S/N Ratio(1KHz A-wt.TH=1%)	>93dB
Channel Separation @1KHz	>104dB
Output signal Crossover	Independent HPF, LPF filter for each channel
	Filter type: Link-Ril, Bessel, Butter-W
	Filter frequency: 20Hz~40KHz (1Hz steps)
	Filter slope: 6dB/Oct~48dB/Oct
Output Signal Equalizer	31 independent equalizers per channel. Type: Parametric / Graphic Equalizer
	Frequency: 20Hz~40KHz (1Hz steps)
	Q Value: 0.404~28.852
	Gain: -12.0dB~+12.0dB (0.1dB steps)
Output Phase	Normal phase or reverse phase (0°~360°)
Output Delay	0.000~20.000ms;0~692cm;0~272.8 inch
Output volume	Each channel independent adjustment: -60dB/Oct~0dB/Oct (0.1dB steps)
	Total volume adjustment: -60dB/Oct~6dB/Oct (0.1dB steps)
Shutdown delay	0~255S
Control	
DSP Tuning	PC software (Installation free) / Smart phone app tuning (External Bluetooth module required)
Remote control	Wired controller / Smart phone app control (External Bluetooth module required)
Dimension	
Net weight	0.96kg
Dimension	137mm x 223mm x 50 mm(L x W x H)

※ SOUNDMAGUS reserves the right to modify specifications or change product design without notice.

EP16S Specification

Power supply	
Operating Voltage range	7.5 - 16V DC
Auto Turn On	ACC / DC OFFSET (High level input CH1 only)
Standby current	<0.5mA
Ldng current	0.44A
REM OUT output voltage	12V DC (380mA)
Input	
Analog input	16 Channel High Level / 10Vrms or 18Vrms
	2 Channel Low Level (AUX) / 2.0Vrms
Digital audio input	1 Optical ; 1 Coaxial
Input Impedance	20K Ohm (Low Level) / 4.7 Ohm(High-Level)
Bluetooth	Built-in Bluetooth 5.1, Supports SBC / AAC protocols
	External Bluetooth 5.0, Supports AAC, APTX-L, APTX-LL, APT-HD, MP3, SBC and other protocols
Output	
Output Channel	16 Channel Low Level
Low level output channel	Output Level 5Vrms (14.4V , 1KHz , 1%THD)
Frequency Response range	20Hz ~ 40KHz (-3dB)
THD (1KHz, 1Vrms output)	0.01%
S/N Ratio(1KHz A-wt.TH=1%)	>95dB
Channel Separation @1KHz	>105dB
Output signal Crossover	Independent HPF, LPF filter for each channel
	Filter type: Link-Ril, Bessel, Butter-W
	Filter frequency: 20Hz~40KHz (1Hz steps)
	Filter slope: 6dB/Oct~48dB/Oct
Output Signal Equalizer	31 independent equalizers per channel. Type: Parametric / Graphic Equalizer
	Frequency: 20Hz~40KHz (1Hz steps)
	Q Value: 0.404~28.852
	Gain: -12.0dB~+12.0dB (0.1dB steps)
Output Phase	Normal phase or reverse phase (0°~360°)
Output Delay	0.000~20.000ms;0~692cm;0~272.8 inch
Output volume	Each channel independent adjustment: -60dB/Oct~0dB/Oct (0.1dB steps)
	Total volume adjustment: -60dB/Oct~6dB/Oct (0.1dB steps)
Shutdown delay	0~255S
Control	
DSP Tuning	PC software (Installation free) / Smart phone app tuning (External Bluetooth module required)
Remote control	Wired controller / Smart phone app control (External Bluetooth module required)
Dimension	
Net weight	1.1kg
Dimension	137mm x 223mm x 50 mm(L x W x H)

※ SOUNDMAGUS reserves the right to modify specifications or change product design without notice.

WARRANTY CARD

Thank you for choosing products from SOUNDMAGUS. To ensure your rights and enjoy comprehensive after-sales service, please pay attention to the following matters:

The correct installation and use of this product will not pose any harm to the safety of your vehicle, and our company does not assume any joint liability other than the product. If you are not familiar with your vehicle structure and electrical equipment, please do not install this product yourself! We strongly suggest you to install our products via our appointed dealers.

The warranty period for this product is 1 year from the date of purchase. If the product malfunctions during the warranty period, which is caused by defective parts or the quality of the product itself, our company will provide free parts and repair.

During the warranty period, if there are any of the following conditions, free warranty cannot be provided:

- ★ The damage which caused by incorrectly installing or using.
- ★ Can't offer the warranty card or there is no stamp on the warranty card.
- ★ The series number and the bar code had been altered or can't be read.
- ★ The products had been repaired or opened by other people who don't have the authorization from us.
- ★ The damage which caused by altering the circuit privately.
- ★ The damage which caused by crash, falling, water inflow, oxidation and other physical damage by human factor.
- ★ The warranty card only subject to product itself, If there is additional service and transport charges, we would collect fees accordingly.

WARRANTY CARD

User's Counterfoil

In order to insure your full warranty service of products, please correctly fill out the following form and conserve it properly. At the same time, you could ask the seller to enter into our official website www.soundmagus.com to perfect the after-sale service of products.

Product Model: _____

Product Series No.: _____ Dealer signature: _____

Installing Date: ____ / ____ / ____ / _____

Installing Shop name: _____

Address of Installing dealers: _____

Installing shop Tel No.: _____ Contact person: _____

User's name: _____ User's Tel No.: _____

Car Model: _____ Plate No.: _____



Shop Counterfoil

Product Model: _____ Product Series No.: _____

Installing Date: ____ / ____ / ____ /

User's name: _____ User's Tel No.: _____

Car Model: _____ Plate No.: _____

产品主要特点

- 采用4层复合PCB板的架构设计，能有效抑制EMC干扰
- 自适应全屏图形化UI智能调音PC软件
- 日本红宝石音频专用滤波电容
- ADI汽车级 SigmaDSP数字音频信号处理器芯片
- AKM 发烧级音频专用芯片，Hifi级ADC/DAC；
- 采用超低失真度运算放大器
- 智能高电平输入检测技术，可自动诊断避免行车电脑报错而无法使用
- 多路高电平信号输入，支持多通道之间任意混频
- 每通道均支持31段EQ、分频器相位、延时，可自定义多组联调
- 内置5.1蓝牙实现数字音频直传
- 可扩展外置 CSR 蓝牙5.0模块，支持AAC, APTX-L, APTX-LL, APT-HD, MP3, SBC等协议。
- 主/辅音源智能混音功能，自动检测原车音源信号和后加装音源信号，实现自由切换、自动混音
- 支持IOS/Android手机调音
- 支持加密DSP调音设置，以防止未经授权的修改
- 智能欠压保护功能



更多产品信息
请关注圣美歌微信公众号

EP12S 产品接口及功能介绍

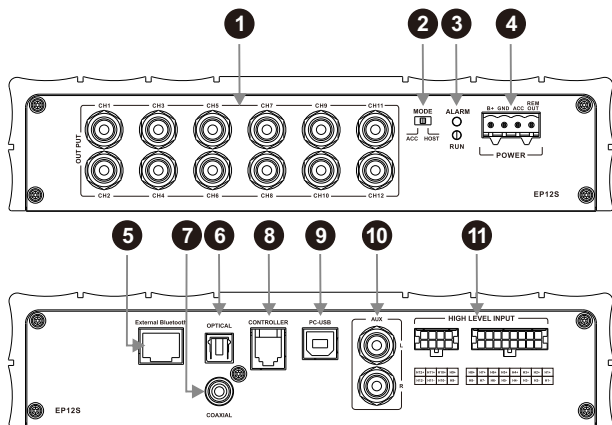

1、OUTPUT（音频输出接口）

前级模拟信号输出端口，输出前级模拟信号给功放等音频系统使用，可扩展连接外置功放。

2、MODE（开机模式选择）

开关拨至“ACC”端时，由原车的ACC信号启动设备；拨至“HOST”端时，由高电平输入信号的CH1启动设备。

3、RUN LED：工作指示灯，当处理器自检完成进入正常工作状态时，蓝色指示灯为常亮状态。

ALARM LED：保护状态指示灯，保护指示灯闪亮时表示处理器处于非正常工作状态，处理器无输出。

4、Power（电源接口）

B+：用于连接12V汽车蓄电池正极端。为确保处理器有充足的电源供应，应使用专用电缆线直接连接于蓄电池的正极，并在距离蓄电池正极端20厘米内串接保险丝。

GND：用于连接处理器接地电缆，电源接地线需要稳固的连接在车体、大梁等导电良好的地方，请使用和电源线相同规格的线缆，在产品安装位置就近连接车体。

ACC：用于连接汽车CD/DVD等音源设备的开关机控制输出信号，产品将随着CD/DVD等音源设备的开关而开关。

REMOUT：提供单独的REMOTE信号输出，可以用来接驳其他功放，通过该REMOTE信号控制其他功放的开机和关机

5、External Bluetooth（外置蓝牙接口）

选择高清蓝牙作为输入信号，同时也可以连接手机APP进行无线调音。

6、OPTICAL（光纤输入接口）

连接车载CD光纤输出端，或者其它具备光纤输出的设备，将DSP功放的音源切换至光纤输入，可播放光纤数字信号。

注意：该接口不能与同轴接口复用。

7、COAXIAL（同轴输入接口）

连接车载CD同轴输出端，或者其它具备同轴输出的设备，将DSP功放的音源切换至同轴输入，可播放同轴数字信号。

注意：请选择阻抗为75Ω的同轴线；该接口不能与光纤接口复用。

8、CONTROLLER（线控器接口）

可通过连接线控器实现总音量、超低音调节，主/辅音源选择，预置音效选择。

9、PC-USB（PC调音接口）

可通过USB2.0线连接电脑，进行专业的调音操作和设置。

10、AUX（辅助音源输入接口）

具备2路RCA音频信号输入，可连接车载CD机的RCA音频信号输出。

11、HIGH LEVEL INPUT（高电平信号输入端口）

支持最多12路高电平信号输入，将原车CD等音源设备的扬声器输出端音频信号连接至DSP的高电平信号输入端。

EP16S 产品接口及功能介绍

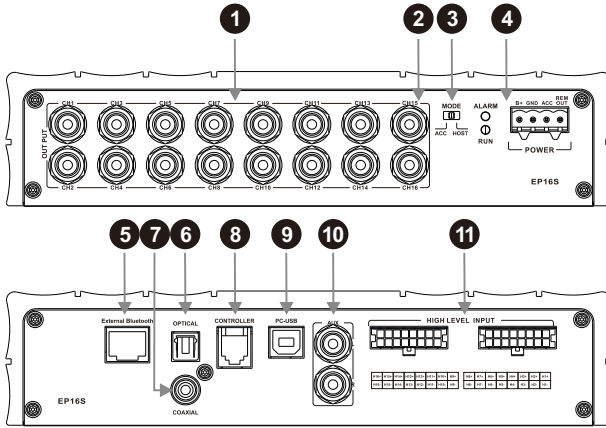

1、OUTPUT（音频输出接口）

前级模拟信号输出端口，输出前级模拟信号给功放等音频系统使用，可扩展连接外置功放。

2、MODE（开机模式选择）

开关拨至“ACC”端时，由原车的ACC信号启动设备；拨至“HOST”端时，由高电平输入信号的CH1启动设备。

3、RUN LED：工作指示灯，当处理器自检完成进入正常工作状态时，蓝色指示灯为常亮状态。

ALARM LED：保护状态指示灯，保护指示灯闪亮时表示处理器处于非正常工作状态，处理器无输出。

4、Power（电源接口）

B+：用于连接12V汽车蓄电池正极端。为确保处理器有充足的电源供应，应使用专用电缆线直接连接于蓄电池的正极，并在距离蓄电池正极端20厘米内串接保险丝。

GND：用于连接处理器接地电缆，电源接地线需要稳固的连接在车体、大梁等导电良好的地方，请使用和电源线相同规格的线缆，在产品安装位置就近连接车体。

ACC：用于连接汽车CD/DVD等音源设备的开关机控制输出信号，产品将随着CD/DVD等音源设备的开关而开关。

REM OUT：提供单独的REMOTE信号输出，可以用来接驳其他功放，通过该REMOTE信号控制其他功放的开机和关机。

5、External Bluetooth（外置蓝牙接口）

选择高清蓝牙作为输入信号，同时也可以连接手机APP进行无线调音。

6、OPTICAL（光纤输入接口）

连接车载CD光纤输出端，或者其它具备光纤输出的设备，将DSP功放的音源切换至光纤输入，可播放光纤数字信号。

注意：该接口不能与同轴接口复用。

7、COAXIAL（同轴输入接口）

连接车载CD同轴输出端，或者其它具备同轴输出的设备，将DSP功放的音源切换至同轴输入，可播放同轴数字信号。

注意：请选择阻抗为75Ω的同轴线；该接口不能与光纤接口复用。

8、CONTROLLER（线控器接口）

可通过连接线控器实现总音量、超低音调节，主/辅音源选择，预置音效选择。

9、PC-USB（PC调音接口）

可通过USB2.0线连接电脑，进行专业的调音操作和设置。

10、AUX（辅助音源输入接口）

具备2路RCA音频信号输入，可连接车载CD机的RCA音频信号输出。

11、HIGH LEVEL INPUT（高电平信号输入端口）

支持最多16路高电平信号输入，将原车CD等音源设备的扬声器输出端音频信号连接至DSP的高电平信号输入端。

功放安装

- 1、翻转功放,使底面向上。
- 2、用随机附件中的4个螺钉将4个固定片安装在功放上指定的位置(图示1), 你可以根据功放的实际安装位置, 灵活选择竖式(安装1)或者横式(安装2)方式把固定片安装在功放上。
- 3、用随机附件中的4个黑色螺钉把功放固定在安装位置上。

(图示1)

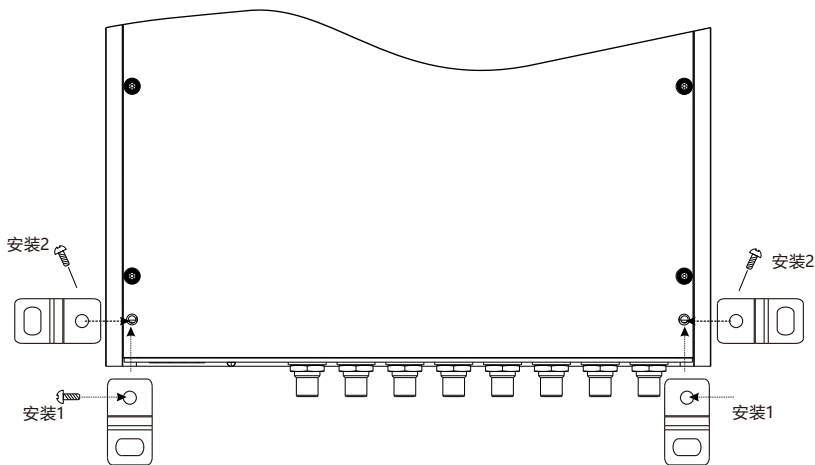

连接操作

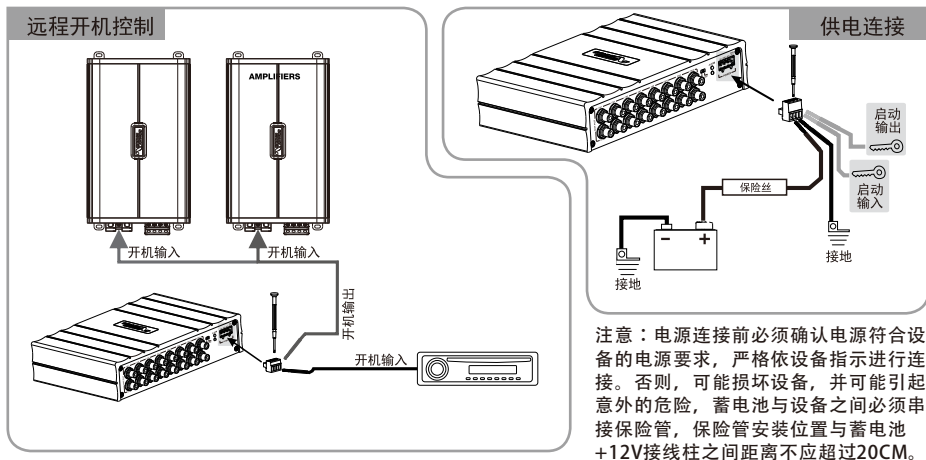

如何控制DSP处理器打开/关闭。

该处理器提供两种开/关机模式给客户选择使用，分别ACC/HOST模式。两种模式的功能介绍请参考“产品接口及功能介绍”项。

电脑软件使用说明

此功能仅供厂商及经销商使用。

软件安装注意事项

1、软件只能在Windows系统下使用。

建议规格：

操作系统：Windows XP / Windows 7 / Windows 8 / Windows 10

CPU：1.6GHz及以上

内存卡：1GB以上

硬盘512MB或更多可用空间

电脑分辨率：1280*768或更高

2、将DSP功放主机与电脑连接前，请先正确安装EP系列的电脑操作软件。



Soundmagus

PC界面介绍

双击电脑桌面Soundmagus软件，进入软件启动界面，首先进入启动画面，选择当前所操作的产品型号，然后进入调音主界面，连接成功后进行详细调音操作。



启动界面，选择设备



主页面

功能介绍（示意图以EP12调音界面为例）

在没有联机前，连接图标显示红色 未连接；成功联机后，连接图标显示绿色 已连接。

菜单栏：文件、选项和加密功能。

1、点击“文件”：



1.1、选择“加载电脑上场景文件”可将以前保存在电脑上的场景文件加载为当前机器工作场景。

1.2、选择“另存为电脑上场景文件”可将当前机器工作场景文件保存到电脑上，以备之后调用。

1.3、选择“加载整机场景”将以前保存在电脑上整套机器的文件加载到机器上（包括当前工作场景、机器预置场景、输出通道配置数据等）即将以前调试好的机器数据全部复制到现在所连接的机器上。

1.4、选择“保存整机场景”将现联机机器上所有数据保存为电脑文件（包括当前工作场景、机器预置场景、输出通道配置数据等），以备之后整机复制时调用。

2、点击“选项”：



2.1、选择“联调设置”进入联调设置界面，选择需要联调的功能项，勾选后可在主页面对所择的功能进行联调。

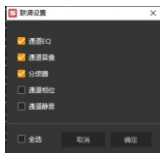

2.2、选择“固件更新”弹出对话框中选择升级文件，再点击“更新”按键即升级固件，升级进度达到100%，表示固件升级成功。更新完成后，机器会自动重新启动。



2.3、选择“高级”项可分别设置“主音源衰减量”，主音源的衰减量越大，“主音量”越小，可调值为0%~100%，默认50%；噪声门开/关；关机延时0~255秒。

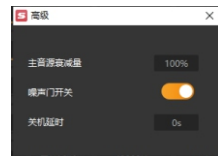

2.4、选择“恢复出厂设置”机器内所有设置的数据恢复到出厂状态。



2.5、选择“语言”进行中文和英文切换。

2.6、选择“关于”可查看设备型号及版本。



3、点击“加密”：

在弹出对话框中输入6位加密密码即可加密已调好的音效数据。



对已加密数据可点击“解密”输入正确的密码进行解密；在解密界面，点击“清空数据”即可一键解除加密状态，并将数据恢复到出厂状态。

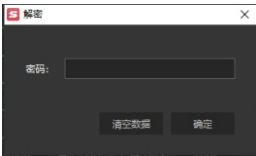

音源选择



1、主音源：点击主音源右侧下拉键头，在弹出窗口中选择主音源：高电平、低电平、光纤、同轴或蓝牙。

2、混音音源（辅助音源）：

2.1、点击混音音源右侧下拉键头，在弹出窗口中选择混音音源：高电平、低电平、光纤、同轴、蓝牙或者关闭，默认为关闭。

2.2、主音源和混音音源都有选择时，需根据实际使用需求在“高级”选项中调节主音源衰减量，主音源衰减量百分值越大，主音量越小，可调值为0%~100%，默认50%。

※注意：当选择当前音源方式时，不可再进行该音源方式的重复，否则辅助音源无效。

总音量设置



可通过按住鼠标左键左右拖动音量推子或滚动鼠标滚轮方式调节总音量大小，亦可直接输入需要的数值来进行调节，调节范围：-60dB(关闭)~6dB，默认0dB。点击总音量喇叭按键可设置总音量静音，再次单击则取消静音，调节总音量时会自动取消静音。

动态响度和空间全景声设置



动态响度：打开动态响度开关，可实现较小增益时仍有较强的低频动态效果。

空间全景声：打开空间全景声开关，可通过点开下拉菜单，最多可控制12个通道开/关，然后再对相应通道全景声参数进行配置。

音效设置

机器内部有6组预置音效的存储空间，点击调用按键 **调用** 或保存按键 **保存**，可设置6组预置音效数据。



通道联调、输出类型、增益、静音和独奏设置



1、联调：点击联调按键 **联调** 在弹出对话框中，选择联调组名，此时通道旁边的联调图标显示相应的组名序号，可任意设置5个联调组，相同组名序号的组表示处于联调状态。如不需要联调，可选择“取消联调”。



注意：联调的项目需先在联调设置列表中预先勾选，详见“联调设置” 2.1。

2、输出类型：点击通道输出类型按键 **前左高频**，在下拉菜单中选择通道类型。前置有高频、中频、中低频、低频和全频可选；后置有高频、中频、中低频、低频和全频可选；中置有前中置高频、前中置中频、后中置高频和后中置中频可选；超低有左超低频、右超低频和超低频可选；环绕有左环绕和右环绕可选。如果需要重新设置各通道类型，可选择 **清空** 或者设置默认。

3、通道增益：可通过直接输入数值、滚动鼠标滚轮、键盘上的上下键设置通道的音量，调节范围：-60dB~0dB，默认0dB。

4、静音：点击音量喇叭按键 **静音** 可使通道静音。

5、独奏：点击通道OFF按键可使该通道有信号输出，状态按键显示ON；同时，其它通道切换到静音状态，相应通道的喇叭按键显示为 **静音**。

分频器设置



1、分频器类型：宁克-锐、巴特沃斯或贝塞尔。

2、频率：可通过直接输入数值、滚动鼠标滚轮、键盘上的上下键或点击EQ上的“H”或“L”按钮按鼠标左键拖动等方式来进行调节频率。

调节范围：EP12S: 20Hz~40000Hz；

EP16S: 20Hz~40000Hz；

3、斜率：6dB/Oct, 12dB/Oct, 18dB/Oct, 24dB/Oct, 30dB/Oct, 36dB/Oct, 42dB/Oct, 48dB/Oct或关闭

说明：斜率为6dB/Oct时，类型显示为“空”。

通道相位、相位均衡和延时设置



- 1、相位：点击按键“+”或“-”按键可对通道进行0/180°的相位切换。
- 2、相位均衡：输出通道可单独相位均衡调节，可调节范围：0°~360°；解决调音过程中所产生的微小的相位偏移。
- 3、延时：可通过直接输入数值、滚动鼠标滚轮、键盘上的上下键来调节延时。更多的延时设置请在延时界面进行，可直接输入数值、滚动鼠标滚轮、键盘的上下键、直接拖动推子调节延时。

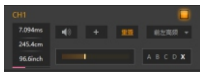

- 3.1、延时群组：每通道可选择设置4个延时群组，可通过点击“X”取消群组通道。
- 3.2、延时单位：毫秒、厘米、英寸。
- 3.3、调节范围：0~20毫秒，0~692厘米，0~272.8英寸。
- 3.4、如果需要重新设置可点击“重置”。

通道EQ设置

通道EQ有图示均衡和参量均衡两个界面



混音设置

EP系列产品均带有混音功能，首先设置好音源，再切换到混音界面，通过所选择的音源设置信号进入音频处理器的各个通道，可单独设置信号到各个输出通道的音量比例，通过调节通道内的各个音源音量比例来达到混音的目的。



参量均衡

每通道具备31段EQ独立可调节。在“参量均衡”状态下，当鼠标移至需要调节的频点并按下，通过上下拖动可调节均衡器的增益，左右拖动可调节均衡器的频率；当鼠标移动至所拾取的频点左右侧橙色小框上，按住左右拖动可调节均衡器的Q值。也可通过直接输入数值、滚动鼠标滚轮、键盘上的上下键来设置频率、Q值和增益。

- 1、频率调节范围：20Hz~40KHz
- 2、Q值调节范围：0.404~28.852，默认1.902；

- 3、增益调节范围：-12dB~+12dB，默认0dB。

当通道EQ有调节时，会出现“直通”均衡按键**直通**，点击“直通”或直通“小圆点”使当前通道的所有均衡器处于不生效状态；

点击“恢复”均衡按键**恢复**使当前通道的所有均衡器回到上次设置状态。点击重置均衡按键**重置**，当前通道的所有均衡器的参数回到初始状态。

图示均衡：该均衡界面下增益可调，频率和Q值固定；参量均衡：该均衡界面下频率、Q值和增益均可调。

输出通道频谱动态显示图（该功能仅EP16S具备）

该窗口仅显示输出通道的频谱动态



- 1、显示窗口：窗口大小可最大屏，可自由缩放。
- 2、选择显示通道：
 - (1) 输出：点击下拉列选择输出通道的频谱动态。
 - (2) 固定：只能显示当前选中输出通道的频谱动态，不可切换其他输出通道。
 - (3) 跟随：可跟随鼠标点击的输出通道来切换显示所选中输出通道的频谱动态。
 - (4) 信号增益：按住鼠标，左右推动推子，可调节信号增益高低。
 - (5) 灵敏度：有高，中，低可选，灵敏度越高，频谱跳动越灵敏。

线控器功能介绍

1.3 寸OLED屏显示

- 支持总音量调整
- 支持超低音音量调整
- 支持一键静音
- 支持音源切换
- 支持预置场景调用
- 接口模式：RJ11

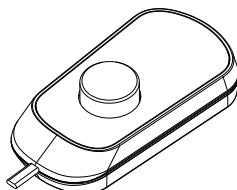

一、线控器操作说明

1、开机启动界面

线控器正常连接启动，显示动态开机启动界面，如下图1所示。



图1

2、主界面

启动完成后，进入线控器主界面：总音量调节界面（可显示输入音源类型）。如图2-1所示，通过旋转线控器按钮可调整音量大小，顺时针方向音量增大，逆时针方向音量减小，音量范围：0~66。在总音量界面下短按按钮实现静音操作，静音界面如图2-2所示。

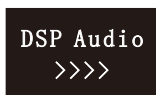

图2-1



图2-2

3、输入音源选择

在主界面下长按按钮进入输入音源界面，如图3所示。通过旋转线控器按钮可选中机器输入音源的类型，长按旋钮可退出该界面，回到线控器主界面。



图3

注意：线控器约5秒不进行任何操作，将自动退出相应界面回到主界面状态。

4、预置音效调用

短按旋钮进入预置音效界面，如图4-1所示，线控器可显示预置音效组，ESC为退出调用，通过旋转按钮选中所需音效，短按按钮进行调用，调用界面如图4-2所示。调用完成后，自动退出该界面，回到线控器主界面。



图4-1



图4-2

5、超低音音量调节

短按线控器按钮可进入超低音音量调节界面，如图5所示，旋转按钮可调整机器低音音量，顺时针方向音量增加，逆时针方向音量减少，调节范围：0~60。长按按钮可退出该界面，回到线控器主界面。



图5

EP12S规格参数

电源部份	
工作电压范围	DC 7.5 -16伏
开机方式	ACC或高电平开机 (CH1通道有效)
待机电流	<0.5毫安
空载电流	0.75安培
REM OUT输出电压	DC12.0伏(380毫安)
输入部份	
模拟输入	12路高电平 / 28Vpp
	2路低电平(AUX) / 5.6Vpp
数字音频输入	1路光纤输入, 1路同轴输入
输入阻抗	低电平: 20K Ω , 高电平: 4.7 Ω
蓝牙	内置蓝牙: Bluetooth5.1, 支持SBC/AAC协议
	外置蓝牙: Bluetooth5.0, 支持AAC/APTX-L/APTX-LL/APT-HD/MP3/SBC等协议
输出部份	
输出通道	12路低电平
低电平输出信号	CH1-CH10输出电平8Vpp, CH11/CH12输出电平15Vpp(14.4V/1KHz/1%THD)
频率响应范围 (-3 dB)	20Hz~ 40KHz
总谐波失真(1KHz,1V额定输出)	0.015%
信噪比(1KHz, A-wt. THD=1%)	>93dB
声道分离度@ 1 KHz	>104dB
输出信号分频器	每个输出通道均具备多阶高低通独立滤波器
	滤波器类型: 宁克-锐 / 巴特沃斯 / 贝塞尔
	滤波器频率: 20Hz~40KHz, 分辨率1Hz
	滤波器斜率: 6dB/Oct~48dB/Oct
输出通道均衡器	每通道独立31段均衡器, 类型: 参量均衡和图示均衡
	频率: 20Hz~40KHz, 分辨率1Hz
	Q值: 0.404~28.852
	增益: -12dB ~ +12dB, 步进: 0.1dB
输出相位	每声道独立调节: 正相/反相; 0~360° 均衡调节
输出延时	每声道独立调节: 0~20ms/0~692cm/0~272.8inch
输出音量	每声道独立调节: -60dB~0dB, 步进: 0.1dB
	总音量调节: -60dB~6dB
关机延时调节范围	0 ~ 255s
控制部份	
调音方式	电脑调音(免驱动) / 手机APP调音(需外接专用蓝牙模块)
远程控制	线控器控制 / 手机APP控制(需外接专用蓝牙模块)
产品规格	
净重	0.96kg
尺寸	137mm x 223mm x 50 mm(长 x 宽 x 高)

※ 规格参数如有更改, 恕不另行通知。

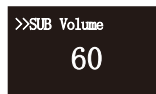
EP16S规格参数

电源部份	
工作电压范围	DC 7.5 -16伏
开机方式	ACC或高电平开机 (CH1通道有效)
待机电流	<0.5毫安
空载电流	0.44安培
REM OUT输出电压	DC12.0伏(380毫安)
输入部份	
模拟输入	16路高电平 / 28Vpp或50Vpp
	2路低电平(AUX) / 5.6Vpp
数字音频输入	1路光纤输入, 1路同轴输入
输入阻抗	低电平: 20K Ω , 高电平: 4.7 Ω
蓝牙	内置蓝牙: Bluetooth5.1, 支持SBC/AAC协议
	外置蓝牙: Bluetooth5.0, 支持AAC/APTX-L/APTX-LL/APT-HD/MP3/SBC等协议
输出部份	
输出通道	16路低电平
低电平输出信号	CH1-CH12输出电平8Vpp, CH13-CH16输出电平15Vpp(14.4V/1KHz/1%THD)
频率响应范围 (-3 dB)	20Hz~ 40KHz
总谐波失真(1KHz,1V额定输出)	0.01%
信噪比(1KHz, A-wt, THD=1%)	>95dB
声道分离度@ 1 KHz	>105dB
输出信号分频器	每个输出通道均具备多阶高通独立滤波器
	滤波器类型: 宁克-锐 / 巴特沃斯 / 贝塞尔
	滤波器频率: 20Hz~40KHz, 分辨率1Hz
	滤波器斜率: 6dB/Oct~48dB/Oct
输出通道均衡器	每通道独立31段均衡器, 类型: 参量均衡和图示均衡
	频率: 20Hz~40KHz, 分辨率1Hz
	Q值: 0.404~28.852
	增益: -12dB ~ +12dB, 步进: 0.1dB
输出相位	每声道独立调节: 正相/反相; 0~360° 均衡调节
输出延时	每声道独立调节: 0~20ms/0~692cm/0~272.8inch
输出音量	每声道独立调节: -60dB~0dB, 步进: 0.1dB
	总音量调节: -60dB~6dB
关机延时调节范围	0 ~ 255s
控制部份	
调音方式	电脑调音(免驱动) / 手机APP调音(需外接专用蓝牙模块)
远程控制	线控器控制 / 手机APP控制(需外接专用蓝牙模块)
产品规格	
净重	1.1kg
尺寸	137mm x 223mm x 50 mm(长 x 宽 x 高)

※ 规格参数如有更改, 恕不另行通知。

产品保修及售后服务

感谢您选购圣美歌公司产品，为确保您的权益并享受完善的售后服务，请注意下列事项：

本公司产品已经获得欧盟国家机车电子产品安全认证及欧盟CE认证，正确安装和使用本产品不会对您的车辆安全构成任何危害，本公司不承担产品之外的其他连带责任。如果您对您的车辆结构和电器设备不熟悉，请不要自己安装本产品！强烈建议您到“圣美歌指定安装店”为您完成系统安装。

本产品自购买日起保修有效期为1年。在保修期内如产品发生故障，属零部件不良或产品本身品质所致，本公司将免费提供零部件并维修。

在保修期内，若有下列状况，恕不能免费保修：

- 1、未按使用说明书要求安装或使用造成的产品损坏。
- 2、未能出示保修卡或者保修卡无经销商印章。
- 3、所填产品型号、机身编号必须与机身编号相符，否则无效。
- 4、外壳及面板划伤碰损等不在保修范围。
- 5、产品经过非我公司授权人员拆装或修理，不在保修之列。
- 6、由于坠落、挤压、漫水、受潮及其他人为造成的损坏不在保修之列。
- 7、由于水灾、火灾、雷击等不可抗力造成的损坏不在保修之列。
- 8、一切人为损坏如：接入不适当的电源、不依照说明书使用、因意外而造成的损坏、非经本公司认可的维修和改装、不适当的安装，本公司将不承担保修服务。
- 9、超过保修期后，用户也可享受本公司提供的服务，但所需要更换的零件费用、检修费用以及运输费用由用户本人承担。

深圳市圣美歌科技有限公司

公司地址：深圳市宝安区福园一路美生云谷科技产业园

公司网址：www.soundmagus.cn

客服热线：0755-84528880



产品保修卡

用户存根

为了确保您的产品能够享受全面的保修服务，请正确填写以下信息并妥善保存此保修卡，同时您也可以要求安装店登录公司网站www.soundmagus.cn，进一步完善您的产品售后服务信息。

产品型号：_____

机身编号：_____

安装日期：_____年____月____日

安装店名称：_____



(安装店盖章后生效)

安装店地址：_____

产品保修卡

安装店电话：_____ 安装店联系人：_____

用户名称：_____ 用户电话：_____

安装车型_____ 车牌号码：_____



安装店存根

产品型号：_____ 机身编号：_____

安装日期：_____年____月____日

用户名称：_____ 用户电话：_____

安装车型：_____ 车牌号码：_____

SOUND MAGUS

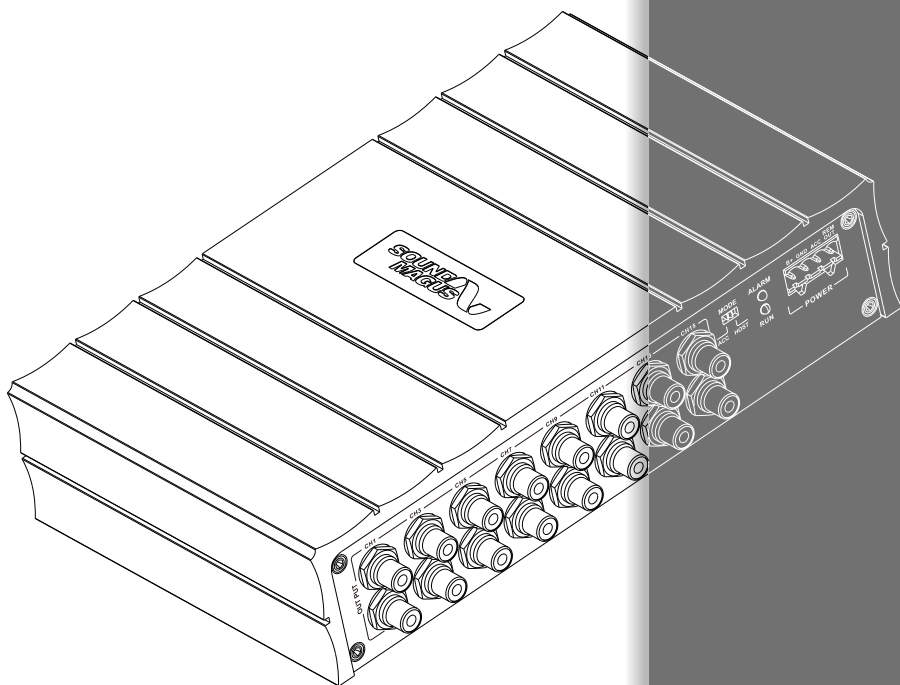

深圳市圣美歌科技有限公司

公司地址：深圳市宝安区福园一路美生云谷科技产业园

公司网址：www.soundmagus.cn

客服热线：0755-84528880